

# IMPORTANT

## READ THIS BEFORE INSTALLING THE FAI-8100 UNIT

**If you do not read the paragraphs below you may blow/demolish your control unit.**

Please read all the supplemental instruction sheets included with the FAI-8100.

Be **EXTREMELY CAREFUL** when connecting both the yellow start kill wire and the GRAY Ignition II wire. **THOSE WIRES HAVE (-) NEGATIVE OUTPUTS.** If you connect them to a positive wire, you will burn a chip inside the control unit. Both the starter kill and Ignition II wires need to be connected to a (-) negative terminal on a relay. (Terminal #85 on the relay.)

If you burn a chip inside the FAI-8100 control unit, we offer the replacement chips at [www.alarmsellout.com/f-repair.htm](http://www.alarmsellout.com/f-repair.htm)

1. DO NOT START INSTALLING THE ALARM UNIT UNTIL YOU HAVE READ AND UNDERSTAND THE INSTALLATION OF THE ALARM.
2. MAKE SURE THE INSTALLER DOES NOT START AND THEN LOOK OVER THE INSTRUCTIONS, AS THIS CAN LEAD TO THE INSTALLER NOT BEING PREPARED AND RESULTING IN MAJOR PROBLEMS. (Ex. Burning a Chip inside the Control Unit.)
3. WE DO NOT OFFER TECH SUPPORT BY PHONE, AS WE ARE ONLY SELLING YOU THE ALARM. THAT IS WHY THE INSTALLER SHOULD BE FAMILIAR WITH THE INSTALLATION DIAGRAM BEFORE ATTEMPTING THE INSTALLATION.
4. HOWEVER, IF YOU DO GET STUCK ON AN INSTALLATION, DON'T FEEL THAT YOU CAN NOT CONTACT US. WE WILL HELP YOU WITH TECHNICAL PROBLEMS TO THE BEST OF OUR ABILITIES. PLEASE VISIT [www.alarmsellout.com/support](http://www.alarmsellout.com/support). PLEASE ONLY EMAIL US ONCE YOU HAVE CHECKED OUR SUPPORT PAGE. TECHNICAL SUPPORT EMAILS NEED TO BE ADDRESSED TO [support@alarmsellout.com](mailto:support@alarmsellout.com). IF YOU HAVE A PROBLEM THAT WE FEEL WE WOULD LIKE TO CONTACT YOU BY PHONE, WE WILL ASK YOU FOR YOUR PHONE NUMBER AND THE BEST TIME TO REACH YOU.
5. IF YOUR INSTALLER HAS INSTALLED THE ALARM CORRECTLY TO THE BEST OF HIS KNOWLEDGE AND THE SYSTEM SEEMS TO BE DEFECTIVE, REMOVE ONLY THE CONTROL UNIT AND EMAIL OUR COMPANY, AS IF THE UNIT IS DEFECTIVE WE WILL GLADLY REPLACE THE CONTROL UNIT WITH A BRAND NEW UNIT. DO NOT HAVE THE INSTALLER REMOVE THE WIRING OR OTHER COMPONENTS, AS THAT IS NOT NECESSARY. A REPLACEMENT OF THE FAULTY UNIT WILL BE GRANTED ONCE OUR COMPANY HAS DETERMINED THE UNIT TO BE COVERED UNDER OUR WARRANTY.
6. IF THE UNIT IS SENT BACK TO US AND WE FIND THE UNIT TO HAVE A PROBLEM THAT WAS CAUSED BY THE INSTALLER, YOU WILL BE CHARGED A SHIPPING FEE TO RETURN THE UNIT TO YOU. WE WILL ALSO GIVE YOU OPTIONS TO HAVE THE UNIT REPAIRED OR REPLACED AT A DISCOUNTED PRICE.
7. **WIRING DIAGRAMS** IF YOU DID NOT RECEIVE A WIRING DIAGRAM FOR YOUR SPECIFIC VEHICLE, YOU CAN REQUEST ONE BY EMAILING US.

@Alarmsellout – Version 1.5

---

*This section was intestinally left blank.*

---

## For Technical Support Questions & Commonly Asked Questions

Please visit: [www.alarmsellout.com/support](http://www.alarmsellout.com/support)

Please do NOT email us until your have checked our support pages for the answer to your question.

# HAND BRAKE / BRAKE PEDAL INSTRUCTIONS

## FOR AUTOMATIC TRANSMISSIONS

Connect the BLACK/RED wire from the Alarm Control Unit to the negative or positive on the brake wire that becomes positive when the brake pedal is pushed down.

\*NOTE: The alarm accepts both positive and negative feeds so it does not matter which your vehicle uses.

\*DO NOT GROUND OUT THE BRAKE PEDAL WIRE AS THE MANUAL TELLS YOU TO DO. That method is not incorrect, but the remote start will only turn off by the remote or when the remote start time expires. By connecting the wire to the brake pedal, the remote start will disengage when you start driving your vehicle.

## FOR MANUAL TRANSMISSIONS

Connect the BLACK/RED wire from the Alarm's Control Unit to the negative or positive parking brake wire.

# OPTIONAL RELAYS – NOT USED WITH MOST VEHICLES

## When Installing a PATS KEY or Passlock Interface System

-When installing a PATS KEY or Passlock Interface System, you do not need to install the Start Kill feature. When the alarm is activated (armed mode,) the PATS KEY or Passlock Interface System will act as the Starter Kill.

-To use the remote start feature, you will need to install a relay to bypass the PATS KEY or Passlock Interface System. This will ONLY disable this security feature during the remote start.

-If your vehicle has a PATS Key, follow the diagram to the right.

-If your vehicle has a Passlock Interface System, follow the directions that came with the wire diagram for your vehicle.

(Diagram #233 or #337 or #338) If you need instructions for a Passlock Interface System, contact sales@alarmsellout.com.

**-NOTE: You will use the relay from the Start Kill feature to install the PATS KEY Bypass System. No additional relays are needed unless you are installing a Passlock Interface System which requires multiple relays.**

### PATS KEY DIAGRAM FOR FAI-8100

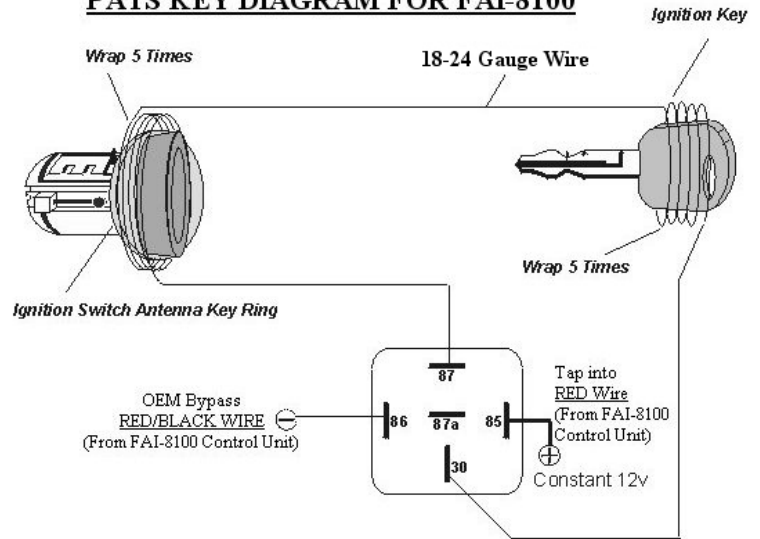

## MANUAL VEHICLES ONLY – To Bypass The Clutch During Remote Start Only – Diagram

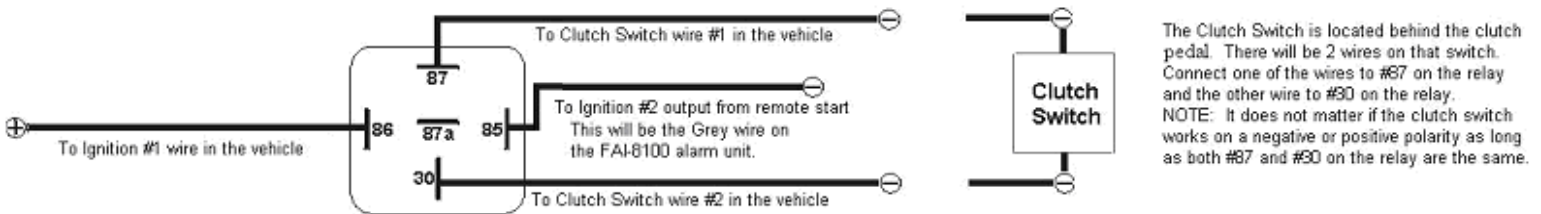

### FAI-8100 Wiring Note #2

Connect the Door-trigger wire to Dome-light or Trunk-trigger wire to Trunk-lamp as follows:

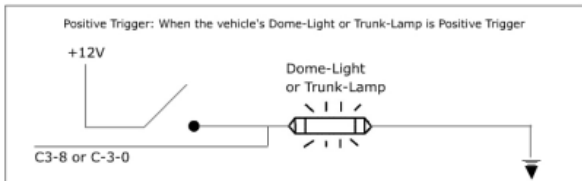
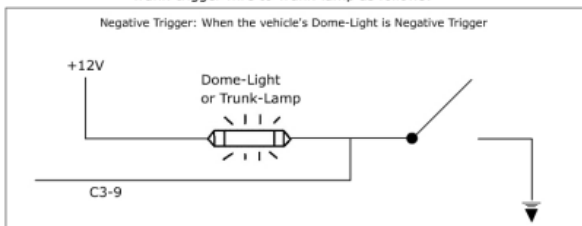

This is the Wiring Note #2 as referred to in the manual.

# Ignition II Wire

**If you do not read the paragraphs below you may blow/demolish your control unit.**

**For Models FAI-8100, FAI-8200**

\* Some vehicles require “extra” ignitions to be powered when remote starting. These “extra” ignitions may be used in the vehicle to power important vehicle circuits such as Power-train Control Modules, Air Bags, Extra H.V.A.C. circuits, or other computer modules in the vehicle.

There are two common methods to connect your vehicle’s Ignition II wire to the FAI Control Unit’s Ignition II wire.

## Method #1 (Most Common Method)

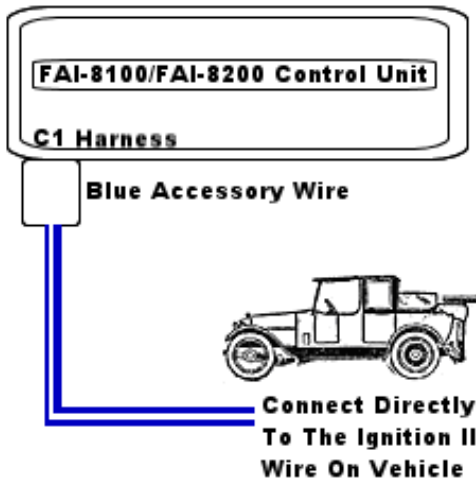

This method will save approximately 30 minutes during the installation and will avoid an unnecessary wiring mess.

Since the accessory wire on your vehicle only operates your radio and other accessories, there is no need to connect the accessory wire to the remote start.

With this method, you will connect the BLUE/White (+) accessory wire from the FAI Control Unit directly to your Ignition II (+) wire on your vehicle.

If you have an Ignition 3 or Ignition 4 wire, you will need to add a relay for the additional Ignitions. Support on this topic can be found at [www.alarmsellout.com/support](http://www.alarmsellout.com/support).

## Method #2 – As Described in The Manual

This method uses the GRAY (-) Ignition II wire from the FAI Control unit. The GRAY (-) Ignition II wire needs to be connected to a negative terminal on a relay (#85.) Connect terminal #30 of the relay to the Ignition #2 wire on your vehicle. Connect Terminal #87 and Terminal #86 to your Ignition #1 wire on your vehicle.

If you have an Ignition 3 or Ignition 4 wire, you will need to add a relay for the additional Ignitions. Support on this topic can be found at [www.alarmsellout.com/support](http://www.alarmsellout.com/support).

**IMPORTANT – Make sure to change the wire in PIN #87a to PIN #87 on the relay socket for the Ignition 2 Relay.**

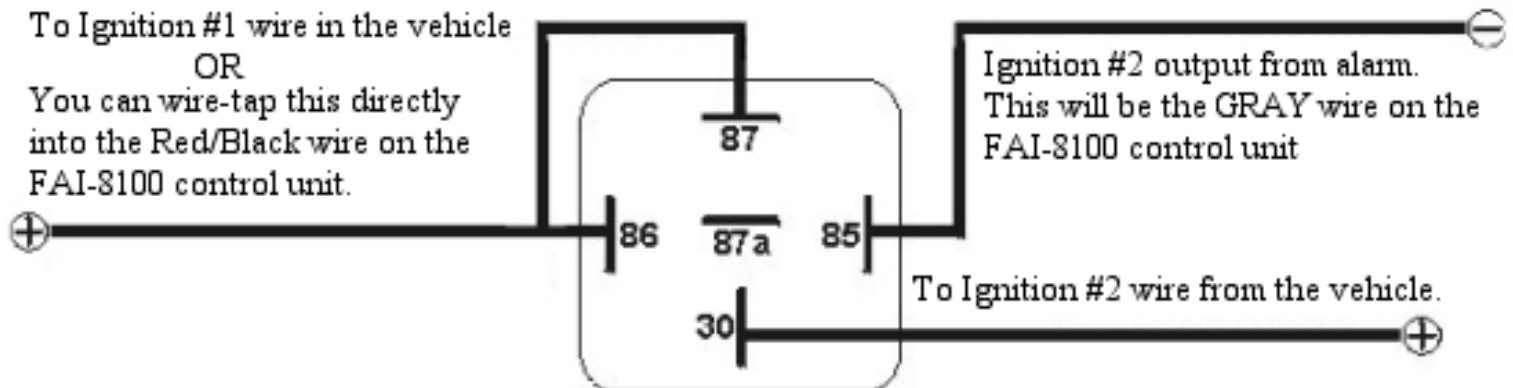

# Door Lock Supplemental Instructions

For Models FAI-8100, FAI-8200, & FAI-820

There are five common methods used to connect your vehicle's power door locks to the FAI Control Units. This is the easiest and most common method used by installers. If this method does not work for you, please refer to the door lock diagrams in your Product Manual.

## Method #1 (Most Common Method)

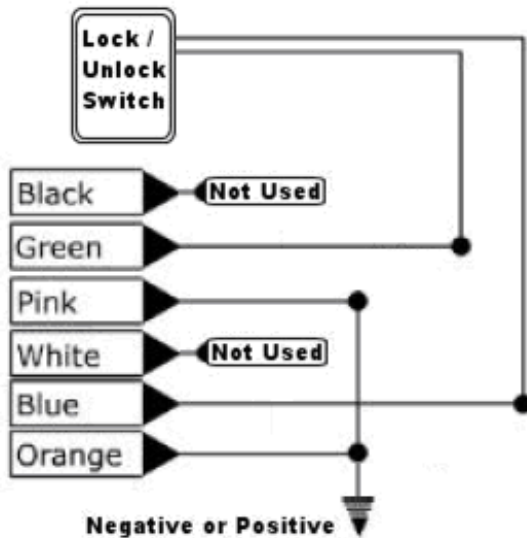

Looking at the FAI door lock harness, you can disregard the Black and White wires as they are not used. You will need to determine if your vehicle uses negative or positive triggers on the electronic lock/unlock switch inside your vehicle. Once you have determined if your vehicle uses a negative or positive trigger to lock and unlock your vehicle, connect the Pink and Orange wires to that same polarity. Connect the GREEN wire to the lock trigger wire on your door lock switch. Connect the BLUE wire to the unlock trigger wire on your door lock switch.

Your vehicle should have 3 wires going to the lock/unlock switch. (Lock, Unlock, and a ground or +12v Constant.) If your vehicle has more than 3 wires, you may need to use a different method.